

GKB OPHTHALMICS LTD ISO 9001 CERTIFIED	TECHNICAL DATA SHEET (PLASTIC)	Doc. No	GKB/O/P/CR-SFKT/13
		Issue No.	06
		Issue Date.	12-04-2024
SEMI-FINISHED CR-39 LENSES			
RI 1.498	LENTICULAR KRYPTOK		67 MM

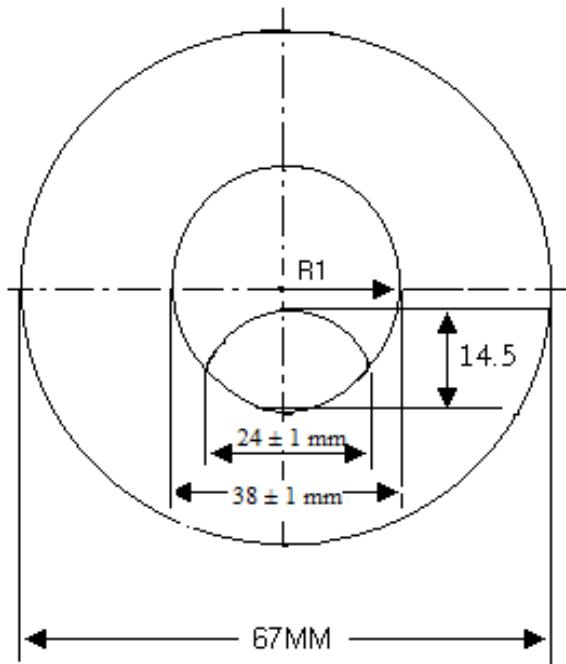

POWER RANGE

Tooling index=1.498

BASE (dpt)	True curve (dpt)	RADIUS OF CURVATURE OF BULGE (mm)	RCC (dpt)	E.T. (mm)
12.00	12.19	40.85	-4.25	9.00
14.00	13.57	36.70	-4.25	9.00
16.00	15.48	32.18	-4.25	9.00
18.00	17.38	28.66	-4.25	9.00
18.00 (Thick)	17.38	28.66	-4.25	12.00

POWER RANGE

BASE (dpt)	ADDITION (dpt)					
	1.50	2.00	2.50	3.00	3.50	4.00
12.00	*	*	*	*	*	*
14.00	*	*	*	*	*	*
16.00	*	*	*	*	*	*
18.00	*	*	*	*	*	*
18.00 (Thick)	*	*	*	*	*	*

Bevel radius for all base curves: 175.95 mm
 ET – EDGE THICKNESS

Prepared by	Approved by	Page 1 of 1
VISHAL MATONKAR	AMOL MANDREKAR	