

GKB OPHTHALMICS LTD ISO 9001 CERTIFIED	TECHNICAL DATA SHEET (PLASTIC)	Doc. No	GKB/O/P/CR-SFSV/07
		Rev No.	07
		Issue Date.	25-07-2024
SEMI-FINISHED CR-39 LENSES			
RI 1.498	LENTICULAR SINGLE VISION		67 MM

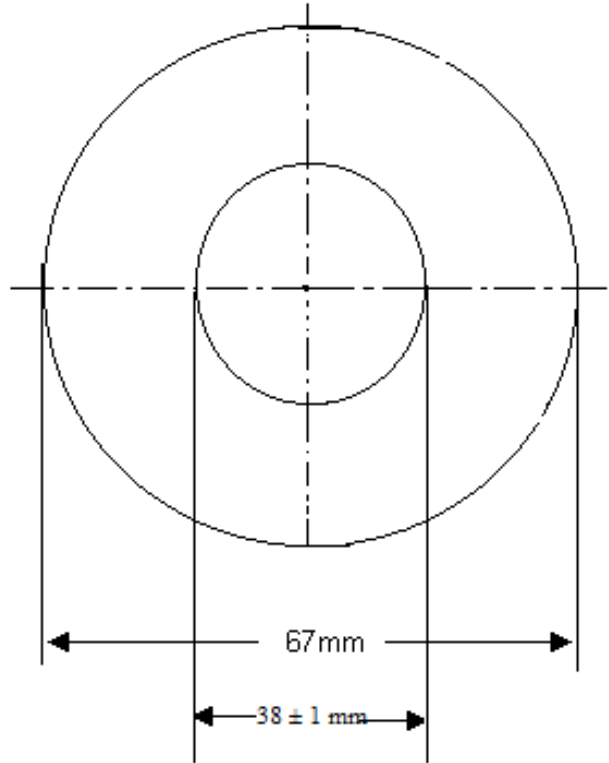

Tooling index = 1.498

BASE (dpt)	True curve (dpt)	RADIUS OF CURVATURE OF BULGE (mm)	Rcc (dpt)	ET (mm)
10.00	9.51	52.35	- 4.25	9.00
12.00	12.19	40.85	- 4.25	9.00
14.00	13.57	36.70	- 4.25	9.00
16.00	15.48	32.18	- 4.25	9.00
18.00	17.38	28.66	- 4.25	9.00
			- 4.25	12.00
20.00	19.04	26.15	- 4.25	12.00
22.00	20.95	23.77	- 4.25	12.00
24.00	22.85	21.79	- 4.25	12.00
26.00	24.78	20.09	- 4.25	12.00

Bevel radius for all base curves: 175.95 mm

ET – EDGE THICKNESS

Prepared by	Approved by	Page 1 of 1
VISHAL MATONKAR	AMOL MANDREKAR	